

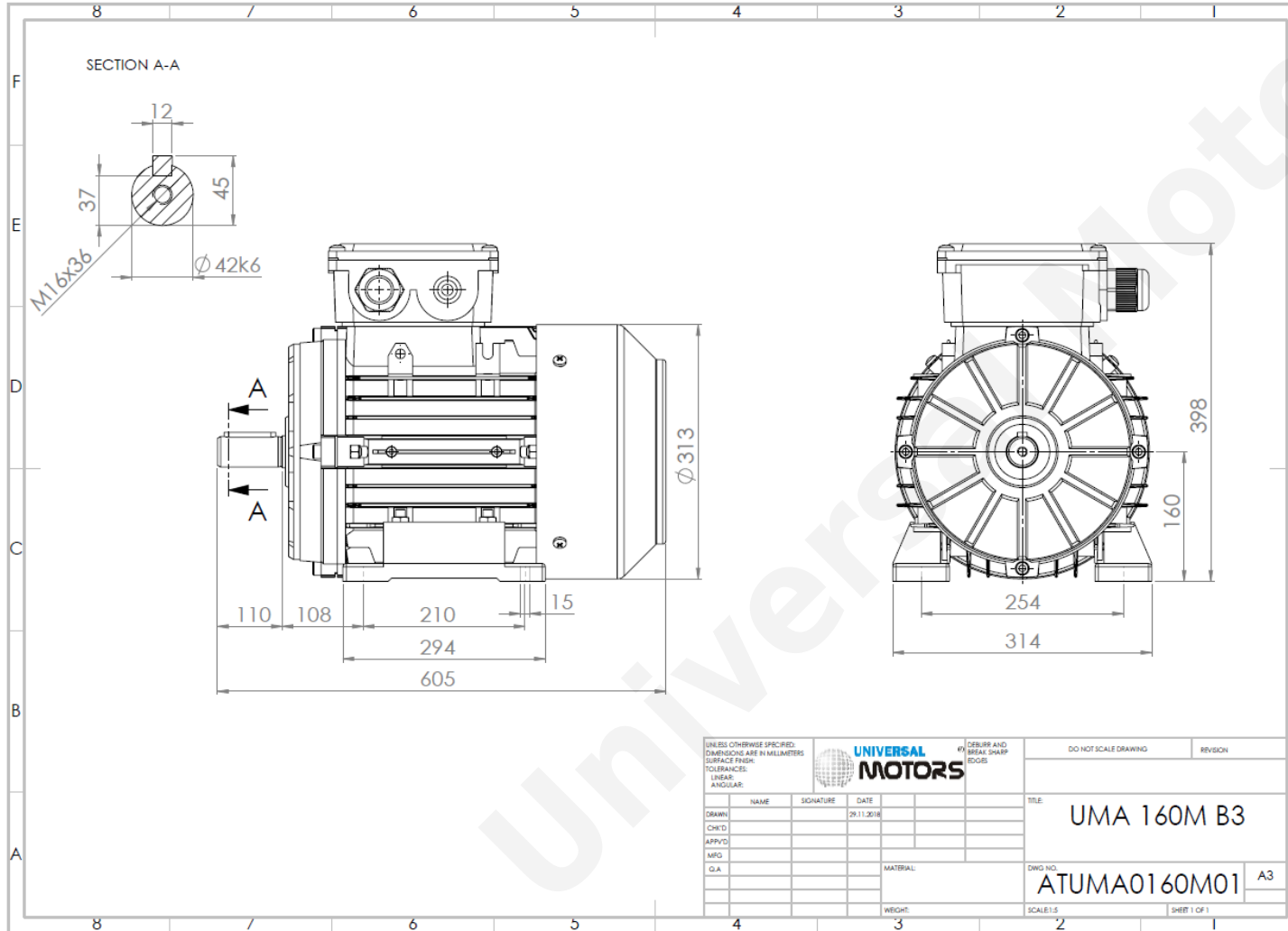

TECHNICAL DATA

Three Phase Electric Motors - Aluminum Frame
 UM2A 160M-4
 11 kW / 15 Cv
 1460 RPM



Motor type:	UM2A 160M-4
Output:	11 kW / 15 Cv
Speed (min ⁻¹):	1460 RPM
Frequency:	50 Hz
Voltage:	400 V
Current:	21.3 A
Power factor (Cos Ø):	0.83
Poles:	4
Insulation class:	F
Temperature rise Class:	B
Efficiency 50%:	90.0 %
Efficiency 75%:	90.4 %
Efficiency 100%:	89.8 %
Torque:	71 N.m
Tstarting/Tnominal:	2.5
Istarting/Inominal:	7.0
Tmaximum/Tnominal:	2.7
Noise:	75 Db(A)
Weight:	82 Kg
Brake AC:	AC8
Torque Brake DC:	200 N.m
Bearing DE:	6309 2Z
Bearing NDE:	6309 2Z
Torque Brake AC:	200 N.m
Brake DC:	K8

Regime - S1

Altitude - 1000m

Environment Temperature - 40°C

CONTACTS:

UNIVERSAL MOTORS Tel: +351 252 299 080
 Rua de São Brás,745 Fax: +351 252 299 089
 4480-782 VILA DO CONDE Mail: geral@universalmotors.pt

* References applied only in the UK